



MULTI MICRO HORNET (ORG1510-R01)

GPS / GNSS MODULE WITH INTEGRATED ANTENNA

Datasheet

OriginGPS.com



INDEX

1.	SCOPE	5
2.	DISCLAIMER	5
3.	SAFETY INFORMATION	5
4.	ESD SENSITIVITY	5
5.	CONTACT INFORMATION.....	5
6.	RELATED DOCUMENTATION	5
7.	REVISION HISTORY	6
8.	GLOSSARY	7
9.	ABOUT HORNET FAMILY	9
10.	ABOUT MULTI MICRO HORNET MODULE	9
11.	ABOUT ORIGINGPS	9
12.	DESCRIPTION	10
12.1.	FEATURES.....	10
13.	ELECTRICAL SPECIFICATIONS	13
13.1.	ABSOLUTE MAXIMUM RATINGS	13
13.2.	RECOMMENDED OPERATING CONDITIONS.....	14
14.	PERFORMANCE	15
14.1.	ACQUISITION TIME	15
14.1.1.	HOT START	15
14.1.2.	SIGNAL REACQUISITION.....	15
14.1.3.	AIDED START	15
14.1.4.	WARM START.....	15
14.1.5.	COLD START	15
14.2.	SENSITIVITY	16
14.2.1.	TRACKING	16
14.2.2.	REACQUISITION	16
14.2.3.	NAVIGATION	16
14.2.4.	HOT START	16
14.2.5.	AIDED START	16
14.2.6.	COLD START	16
14.3.	RECEIVED SIGNAL STRENGTH	17
14.4.	POWER CONSUMPTION (WITH EXTERNAL 1.8V LDO)	17
14.5.	ACCURACY	18
14.6.	DYNAMIC CONSTRAINS.....	18
15.	POWER MANAGEMENT	19
15.1.	POWER STATES	19
15.1.1.	FULL POWER ACQUISITION.....	19
15.1.2.	FULL POWER TRACKING.....	19
15.1.3.	CPU ONLY.....	19
15.1.4.	STANDBY.....	19
15.1.5.	HIBERNATE.....	19
15.2.	BASIC POWER SAVING MODE	19
15.3.	SELF MANAGED POWER SAVING MODES	20
15.3.1.	ADAPTIVE TRICKLE POWER (ATP™)	20
15.3.2.	PUSH TO FIX (PTF™)	20
15.3.3.	ADVANCED POWER MANAGEMENT (APM™)	21
16.	EXTENDED FEATURES	22
16.1.	ALMANAC BASED POSITIONING (ABP™).....	22
16.2.	ACTIVE JAMMER DETECTOR AND REMOVER.....	22
16.3.	CLIENT GENERATED EXTENDED EPHEMERIS (CGEE™)	22
16.4.	SERVER GENERATED EXTENDED EPHEMERIS (SGEE™)	22
17.	INTERFACE	23
17.1.	PAD ASSIGNMENT.....	23
17.2.	POWER SUPPLY	24
17.2.1.	VCC = 1.8V	24



17.2.2.	GROUND	24
17.3.	CONTROL INTERFACE.....	24
17.3.1.	ON_OFF.....	24
17.3.2.	WAKEUP.....	25
17.3.3.	RESET	25
17.3.4.	1PPS	25
17.4.	DATA INTERFACE	26
17.4.1.	UART	26
17.4.2.	SPI	26
17.4.3.	I ² C.....	26
18.	TYPICAL APPLICATION CIRCUIT.....	27
19.	RECOMMENDED PCB LAYOUT	27
20.	DESIGN CONSIDERATIONS	27
21.	OPERATION	28
21.1.	STARTING THE MODULE	28
21.2.	AUTONOMOUS POWER ON	29
21.3.	VERIFYING THE MODULE HAS STARTED	29
21.3.1.	UART	29
21.3.2.	I ² C.....	29
21.3.3.	SPI	29
21.4.	CHANGING PROTOCOL AND BAUD RATE ¹	30
21.5.	CHANGING SATELLITE CONSTELLATION ¹	30
21.6.	SHUTTING DOWN THE MODULE	30
22.	FIRMWARE.....	31
22.1.	DEFAULT SETTINGS	31
22.2.	FIRMWARE UPDATES.....	31
23.	HANDLING INFORMATION.....	32
23.1.	MOISTURE SENSITIVITY.....	32
23.2.	ASSEMBLY	32
23.3.	SOLDERING	32
23.4.	CLEANING	34
23.5.	REWORK.....	34
23.6.	ESD SENSITIVITY.....	34
23.7.	SAFETY INFORMATION	34
23.8.	DISPOSAL INFORMATION	34
24.	MECHANICAL SPECIFICATIONS	35
25.	COMPLIANCE	35
26.	PACKAGING AND DELIVERY	36
26.1.	APPEARANCE	36
26.2.	CARRIER TAPE	37
26.3.	REEL	37
27.	ORDERING INFORMATION.....	38
28.	I2C APPENDIX.....	41



TABLE INDEX

TABLE 1 – RELATED DOCUMENTATION	5
TABLE 2 – REVISION HISTORY	6
TABLE 3 – ABSOLUTE MAXIMUM RATINGS	13
TABLE 4 – RECOMMENDED OPERATING CONDITIONS	14
TABLE 5 – ACQUISITION TIME.....	15
TABLE 6 – SENSITIVITY	16
TABLE 7 – RECEIVED SIGNAL STRENGTH.....	17
TABLE 8 – POWER CONSUMPTION	17
TABLE 9 – ACCURACY.....	18
TABLE 10 – DYNAMIC CONSTRAINS	18
TABLE 11 – PIN-OUT	23
TABLE 12 – HOST INTERFACE SELECT.....	26
TABLE 13 – START-UP TIMING	29
TABLE 14 – DEFAULT FIRMWARE SETTINGS	31
TABLE 14 – SOLDERING PROFILE PARAMETERS.....	33
TABLE 16 – MECHANICAL SUMMARY	35
TABLE 17 – REEL QUANTITY	36
TABLE 18 – CARRIER TAPE DIMENSIONS	37
TABLE 19 – REEL DIMENSIONS.....	37
TABLE 20 – ORDERING OPTIONS.....	38
TABLE 21 – ORDERABLE DEVICES.....	38

FIGURE INDEX

FIGURE 1 – ORG1510 ARCHITECTURE.....	11
FIGURE 2 – SiRFstarV™ 5e GNSS SoC BLOCK DIAGRAM.....	12
FIGURE 3 – ATP™ TIMING	20
FIGURE 4 – PTF™ TIMING.....	20
FIGURE 5 – APM™ TIMING.....	21
FIGURE 6 – ACTIVE JAMMER DETECTOR FREQUENCY PLOT	22
FIGURE 7 – PAD ASSIGNMENT	23
FIGURE 8 – ON_OFF TIMING.....	24
FIGURE 9 – REFERENCE SCHEMATIC DIAGRAM, UART	27
FIGURE 10 – ON_OFF TIMING.....	28
FIGURE 11 – START-UP TIMING	28
FIGURE 12 – RECOMMENDED SOLDERING PROFILE.....	33
FIGURE 13 – MECHANICAL DRAWING	33
FIGURE 14 – MODULE POSITION	38
FIGURE 15 – CARRIER TAPE.....	39
FIGURE 16 – REEL.....	39



1. SCOPE

This document describes the features and specifications of Multi Micro Hornet ORG1510 GPS / GNSS module with integrated antenna.

2. DISCLAIMER

All trademarks are properties of their respective owners.

Performance characteristics listed in this document do not constitute a warranty or guarantee of product performance. OriginGPS assumes no liability or responsibility for any claims or damages arising out of the use of this document, or from the use of integrated circuits based on this document.

OriginGPS assumes no liability or responsibility for unintentional inaccuracies or omissions in this document. OriginGPS reserves the right to make changes in its products, specifications and other information at any time without notice.

OriginGPS reserves the right to conduct, from time to time, and at its sole discretion, firmware upgrades. As long as those FW improvements have no material change on end customers, PCN may not be issued. OriginGPS navigation products are not recommended to use in life saving or life sustaining applications.

3. SAFETY INFORMATION

Improper handling and use can cause permanent damage to the product.

4. ESD SENSITIVITY

This product is ESD sensitive device and must be handled with care.



5. CONTACT INFORMATION

Support - support@origingps.com or [Online Form](#)

Marketing and sales - marketing@origingps.com

Web – www.origingps.com

6. RELATED DOCUMENTATION

No	DOCUMENT NAME
1	Multi Micro Hornet – ORG1510 Evaluation Kit Datasheet
2	Spider and Hornet - NMEA Protocol Reference Manual
3	Spider and Hornet - One Socket Protocol Reference Manual
4	Spider and Hornet - OSP® GNSS Extensions Reference Manual
5	Spider and Hornet Low Power Operating Mode Application Note - SiRFStar V
6	SiRFLive FAQ

TABLE 1 – RELATED DOCUMENTATION



7. REVISION HISTORY

REVISION	DATE	CHANGE DESCRIPTION	Author
1.0	June 4, 2015	First release	Yotam
1.1	June 21, 2015	Minor corrections	Yotam
1.2	January 19, 2016	Power modes and temperature data update	Mark K.
1.3	April 12, 2016	RAM information correction	Ori
1.4	July 4, 2016	Removal of 'Smart data logging to external memory' from features' list. Default interface update – UART	Mark K.
1.5	August 1, 2016	I2C – removal of slave mode	Mark K.
1.6	October 18, 2016	Figure13 – Typical PCB stack-up update	Mark K.
1.7	December 1, 2016	Figure 9A/B/C update – UART, I2C and SPI	Mark K.
1.8	March 30, 2017	Related documents update, Mechanical Specifications update – toerances. EVP ground plane vias – figures update Inrush current update ABP update	Mark K.
1.9	July 20, 2017	Typical Application Circuit update Soldering profile update	Mark K.
2.0	October 10, 2017	MID 178 update Tables 8,9 footnotes update Default interface update – SPI	Mark K.
2.1	March 12, 2018	Update Murata filter p/n	Gil M.
2.2	May 22, 2018	Update Typical Application Circuit schematics	Gil M
2.3 / 2.4	June 27, 2018	Update I2C info	Gil M
2.5	December ,2018	Update PCB layout	Gil M.
2.6	February, 2019	Update Sensitivity	Igor M.
2.7	September 5, 2019	Update PCB Layout link	Ron T.
2.8	August 27, 2020	Update Firmware Updates	Ron T.
2.9	October 6, 2020	Update Ordering information	Ron T.
3.0	December 1, 2020	Update Ordering information	Ron T.

TABLE 2 – REVISION HISTORY

8. GLOSSARY

A-GPS Assisted **GPS**
ABP™ Almanac **B**ased **P**osition
AC Alternating **C**urrent
ADC Analog to **D**igital **C**onverter
AGC Automatic **G**ain **C**ontrol
APM™ Adaptive **P**ower **M**anagement
ATP™ Adaptive **T**rickle **P**ower
BE Broadcast **E**phemeris
BPF Band **P**ass **F**ilter
C/N₀ Carrier to **N**oise density ratio [dB-Hz]
CDM Charged **D**evice **M**odel
CE European Community conformity mark
CEP Circular **E**rror **P**robability
CGEE™ Client **G**enerated **E**xtended **E**phemeris
CMOS Complementary **M**etal-**O**xide **S**emiconductor
CPU Central **P**rocessing **U**nit
CTS Clear-**T**o-**S**end
CW Continuous **W**ave
DC Direct **C**urrent
DR Dead **R**eckoning
DSP Digital **S**ignal **P**rocessor
ECEF Earth **C**entred **E**arth **F**ixed
ECHA European **C**hemical **A**gency
EE Extended **E**phemeris
EGNOS European **G**eostationary **N**avigation **O**verlay **S**ervice
EIA Electronic **I**ndustries **A**lliance
EMC Electro-**M**agnetic **C**ompatibility
EMI Electro-**M**agnetic **I**nterference
ENIG Electroless **N**ickel **I**mmersion **G**old
ESD Electro-**S**tatic **D**ischarge
ESR Equivalent **S**eries **R**esistance
EU European **U**ion
EVB Evaluation **B**oard
EVK Evaluation **K**it
FCC Federal **C**ommunications **C**ommission
FSM Finite **S**tate **M**achine
GAGAN **G**PS **A**ided **G**eo-**A**ugmented **N**avigation
GNSS Global **N**avigation **S**atellite **S**ystem
GPIO General **P**urpose **I**nterface or **O**utput
GPS Global **P**ositioning **S**ystem
HBM Human **B**ody **M**odel
I²C Inter-**I**ntegrated **C**ircuit
I/O Input or **O**utput
IC Integrated **C**ircuit
ICD Interface **C**ontrol **D**ocument
IF Intermediate **F**requency
ISO International **O**rganization for **S**tandardization
JEDEC Joint **E**lectron **D**evice **E**ngineering **C**ouncil
KA Keep **A**live
KF Kalman **F**ilter



LDO Low Dropout regulator
LGA Land Grid Array
LNA Low Noise Amplifier
LP Low Power
LS Least Squares
MID Message Identifier
MM Machine Model
MPM™ Micro Power Mode
MSAS Multi-functional Satellite Augmentation System
MSB Most Significant Bit
MSL Moisture Sensitivity Level
NFZ™ Noise-Free Zones System
NMEA National Marine Electronics Association
OSP® One Socket Protocol
PCB Printed Circuit Board
PLL Phase Lock Loop
PMU Power Management Unit
POR Power-On Reset
PPS Pulse Per Second
PRN Pseudo-Random Noise
PTF™ Push-To-Fix
QZSS Quasi-Zenith Satellite System
RAM Random Access Memory
REACH Registration, Evaluation, Authorisation and Restriction of Chemical substances
RF Radio Frequency
RHCP Right-Hand Circular Polarized
RMS Root Mean Square
RoHS Restriction of Hazardous Substances directive
ROM Read-Only Memory
RTC Real-Time Clock
RTS Ready-To-Send
SAW Surface Acoustic Wave
SBAS Satellite-Based Augmentation Systems
SGEE™ Server Generated Extended Ephemeris
SID Sub-Identifier
SIP System In Package
SMD Surface Mounted Device
SMPS Switched Mode Power Supply
SMT Surface-Mount Technology
SOC System On Chip
SPI Serial Peripheral Interface
SSB® SiRF Standard Binary
SV Satellite Vehicle
TCXO Temperature-Compensated Crystal Oscillator
TTF Time To First Fix
TTL Transistor-Transistor Logic
UART Universal Asynchronous Receiver/Transmitter
VCCI Voluntary Control Council for Interference by information technology equipment
VEP Vertical Error Probability
VGA Variable-Gain Amplifier
WAAS Wide Area Augmentation System



9. ABOUT HORNET FAMILY

OriginGPS GNSS receiver modules have been designed to address markets where size, weight, stand-alone operation, highest level of integration, power consumption and design flexibility - all are very important.

OriginGPS' Hornet family breaks size barrier, offering the industry's smallest fully-integrated, highly-sensitive GPS and GNSS modules with integrated antennas or on-board RF connectors.

Hornet family features OriginGPS' proprietary NFZ™ technology for high sensitivity and noise immunity even under marginal signal condition, commonly found in urban canyons, under dense foliage or when the receiver's position in space rapidly changes.

Hornet family enables the shortest TTM (Time-To-Market) with minimal design risks.

Just connect power supply on a single layer PCB.

10. ABOUT MULTI MICRO HORNET MODULE

Micro Hornet is a complete SiP featuring miniature LGA SMT footprint designed to commit unique integration features for high volume cost sensitive applications.

Designed to support compact and traditional applications such as smart watches, wearable devices, asset trackers, Multi Micro Hornet ORG1510 module is a miniature multi-channel GPS/ GLONASS with SBAS, QZSS and other regional overlay systems receiver that continuously tracks all satellites in view, providing real-time positioning data in industry's standard NMEA format.

Multi Micro Hornet ORG1510 module offers superior sensitivity and outstanding performance, achieving rapid TTFF in less than one second, accuracy of approximately two meters, and tracking sensitivity of -165dBm.

Sized only 10mm x 10mm Multi Micro Hornet ORG1510 module is industry's small sized, record breaking solution.

Multi Micro Hornet module integrates OriginGPS proprietary on-board GPS antenna, dual-stage LNA, RF LDO, SAW filter, TCXO, RTC crystal and RF shield with market-leading SiRFstarV™ GNSS SoC.

Multi Micro Hornet ORG1510 module is introducing industry's lowest energy per fix ratio, unparalleled accuracy and extremely fast fixes even under challenging signal conditions, such as in built-up urban areas, dense foliage or even indoor.

Integrated GPS SoC incorporating high-performance microprocessor and sophisticated firmware keeps positioning payload off the host, allowing integration in embedded solutions with low computing resources.

Innovative architecture can detect changes in context, temperature, and satellite signals to achieve a state of near continuous availability by maintaining and opportunistically updating its internal fine time, frequency, and satellite ephemeris data while consuming mere microwatts of battery power.

11. ABOUT ORIGINGPS

OriginGPS is a world leading designer, manufacturer and supplier of miniature positioning modules, antenna modules and antenna solutions.

OriginGPS modules introduce unparalleled sensitivity and noise immunity by incorporating Noise Free Zone system (NFZ™) proprietary technology for faster position fix and navigation stability even under challenging satellite signal conditions.

Founded in 2006, OriginGPS is specializing in development of unique technologies that miniaturize RF modules, thereby addressing the market need for smaller wireless solutions.



12. DESCRIPTION

12.1. FEATURES

- + Autonomous operation
- + Pin to pin compatible with ORG1410 GPS module
- + OriginGPS Noise Free Zone System (NFZ™) technology
- + Fully integrating:
 - Antenna element, Dual-stage LNA, SAW filter, TCXO, RTC crystal, GNSS SoC, LDO regulator, RF shield
- + GPS L1 1575.42 frequency, C/A code
- + GLONASS L1 FDMA 1598-1606MHz frequency band, SP signal
- + SBAS (WAAS, EGNOS, MSAS) and QZSS support
- + Concurrent tracking of multiple constellations
- + 52 channels
- + Ultra-high Sensitivity down to -165dBm enabling Indoor Tracking
- + TTFF of < 1s in 50% of trials under Hot Start conditions
- + Low Power Consumption of $\leq 15\text{mW}$ in ATP™ mode
- + High Accuracy of < 1.5m in 50% of trials
- + High update rate of 5Hz, 1Hz by default
- + Autonomous A-GNSS by Client Generated Extended Ephemeris (CGEE™) for non-networked devices
- + Predictive A-GNSS by Server Generated Extended Ephemeris (SGEE™) for connected devices
- + Ephemeris Push™ for storing and loading broadcast ephemeris
- + Host controlled power saving mode
- + Self-managed low power modes - ATP™, PTF™ and APM™.
- + Almanac Based Positioning (ABP™)
- + Multipath and cross-correlation mitigation
- + Active Jammer Detector and Remover
- + Fast Time Synchronization for rapid single satellite time solution
- + Selectable UART, SPI or I²C host interface
- + NMEA protocol by default, switchable into One Socket Protocol (OSP®)
- + Programmable baud rate and messages rate
- + 1PPS Output
- + Single voltage supply 1.8V
- + Ultra-small LGA footprint of 10mm x 10mm
- + Ultra-low weight of 2.5g
- + Surface Mount Device (SMD)
- + Optimized for automatic assembly and reflow equipment
- + FCC, CE, VCCI compliant
- + RoHS II/REACH compliant

12.2. ARCHITECTURE

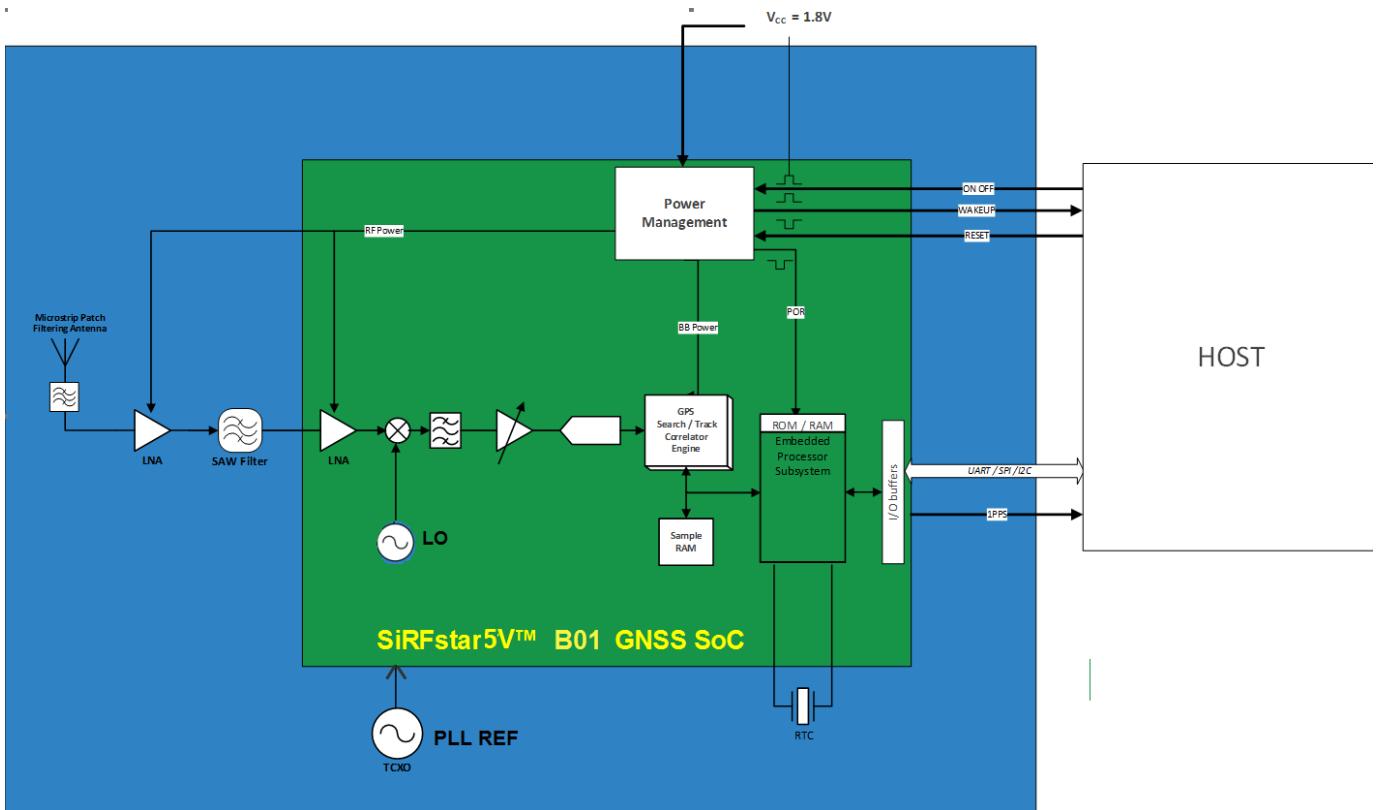

FIGURE 1 – ORG1510 ARCHITECTURE

+ Antenna

OriginGPS proprietary Microstrip Patch Antenna collects GNSS signals from the medium. Antenna is built from hi-K ceramic element mounted on top of RF shield, providing stable resonance.

+ GNSS SAW Filter

Band-Pass SAW filter eliminates out-of-band signals that may interfere to GNSS reception. GNSS SAW filter is optimized for low Insertion Loss in GNSS band and low Return Loss outside it.

+ GNSS LNA

Dual-stage cascaded LNAs amplify GNSS signals to meet RF down converter input threshold. Noise Figure optimized design was implemented to provide maximum sensitivity.

+ TCXO

Highly stable 26MHz oscillator controls down conversion process in RF block of the GNSS SoC. Characteristics of this component are important factors for higher sensitivity, shorter TTFF and better navigation stability.

+ RTC crystal

Tuning fork 32.768KHz quartz crystal with very tight specifications is necessary for maintaining Hot Start and Warm Start capabilities of the module.

+ LDO regulator (optional)

RF LDO provides regulated voltage supply over wide input voltage range, with low quiescent current and high PSRR.

+ RF Shield

RF enclosure avoids external interference from compromising sensitive circuitry inside the module. RF shield also blocks module’s internal high frequency emissions from being radiated.

+ SiRFstarV™ 5e GNSS SoC

CSR 5e is a 5-th generation SiRFstar™ product.

It is a hybrid positioning processor that combines GPS, GLONASS, SBAS and MEMS sensor data to provide a high performance navigation solution.

SiRFstarV™ 5e is a full SoC built on a low-power RF CMOS single-die, incorporating GNSS RF, GNSS baseband, integrated navigation solution software and ARM® processor.



FIGURE 2 – SiRFstarV™ 5e GNSS SoC BLOCK DIAGRAM

SiRFstarV™ 5e SoC includes the following units:

- + GNSS radio subsystem** containing single input dual receive paths for concurrent GPS and GLONASS, harmonic-reject double balanced mixer, fractional-N synthesizer, integrated self-calibrating filters, IF VGA with AGC, high-sample rate ADCs with adaptive dynamic range.
- + Measurement subsystem** including DSP core for GNSS signals acquisition and tracking, interference scanner and detector, wideband and narrowband interference removers, multipath and cross-correlation detectors, dedicated DSP code ROM and DSP cache RAM.
- + Measurement subsystem** interfaces GNSS radio subsystem.
- + Navigation subsystem** comprising ARM7® microprocessor system for position, velocity and time solution, program ROM, data RAM, cache and patch RAM, MEMS sensor driver, SPI flash driver, host interface UART, SPI and I²C drivers.
- + Navigation subsystem** interfaces measurement subsystem.

- + Auxiliary subsystem containing RTC block and health monitor, temperature sensor for reference clock compensation, battery-backed SRAM for satellite data storage, voltage supervisor with POR, PLL controller, GPIO controller, 48-bit RTC timer and alarms, CPU watchdog monitor.
- + Auxiliary subsystem interfaces navigation subsystem, PLL and PMU subsystems.
- + PMU subsystem containing voltage regulators for RF and baseband domains.

13. ELECTRICAL SPECIFICATIONS

13.1. ABSOLUTE MAXIMUM RATINGS

Stresses exceeding Absolute Maximum Ratings may damage the device.

PARAMETER		SYMBOL	MIN	MAX	UNIT	
Power Supply Voltage		V_{CC}	-0.30	+2.20	V	
Power Supply Current ¹		I_{CC}		300	mA	
RF Input Voltage		V_{RF}	-25	+25	V	
I/O Voltage		V_{IO}	-0.30	+3.65	V	
I/O Source/Sink Current		I_{IO}	-4	+4	mA	
ESD Rating	I/O pads	HBM ⁴ method	$V_{IO(ESD)}$	-2000	+2000	V
		CDM ⁵ method		-400	+400	V
	Power pads	HBM ⁴ method	$V_{CC(ESD)}$	-2000	+2000	V
		CDM ⁵ method		-500	+500	V
	RF ²	HBM ⁴ method	$V_{RF(ESD)}$	-2000	+2000	V
		MM ⁶ method		-100	+100	V
RF Power ³	$f_{IN} = 1560\text{MHz} \div 1630\text{MHz}$		P_{RF}		+10	dBm
	$f_{IN} < 1560\text{MHz}, > 1630\text{MHz}$				+30	dBm
Power Dissipation		P_D		350	mW	
Operating Temperature		T_{AMB}	-40	+85	°C	
Storage Temperature		T_{ST}	-55	+125	°C	
Lead Temperature ⁴		T_{LEAD}		+250	°C	

TABLE 3 – ABSOLUTE MAXIMUM RATINGS

Notes:

1. Inrush current of up to 300mA for about 20µs duration.
2. Voltage applied on antenna element.
3. Power delivered to antenna element.
4. Human Body Model (HBM) contact discharge per EIA/JEDEC JESD22-A114D.
5. Charged Device Model (CDM) contact discharge per EIA/JEDEC JESD22-C101.
6. Machine Model (MM) contact discharge per EIA/JEDEC JESD22-A115C.
7. Lead temperature at 1mm from case for 10s duration.

13.2. RECOMMENDED OPERATING CONDITIONS

Exposure to stresses above Recommended Operating Conditions may affect device reliability.

PARAMETER	SYMBOL	MODE / PAD	TEST CONDITIONS	MIN	TYP	MAX	UNIT	
Power supply voltage	V _{CC}	V _{CC}		+1.71	+1.80	+1.89	V	
Power Supply Current ¹	I _{CC}	Acquisition	GPS		45		mA	
			GPS+GLONASS		55		mA	
		Tracking	GPS		40		mA	
			GPS+GLONASS		50		mA	
		ATP™ Tracking ²			8		mA	
		CPU only ³			15		mA	
		Standby ³					0.1	mA
		PTF™ ⁴				0.45		mA
		Hibernate			50	54	μA	
Input Voltage Low State	V _{IL}	GPIO		-0.30		+0.40	V	
Input Voltage High State	V _{IH}			0.70·V _{CC}		+3.60	V	
Output Voltage Low State	V _{OL}		I _{OL} = 2mA			+0.40	V	
Output Voltage High State	V _{OH}		I _{OH} = -2mA	0.75·V _{CC}			V	
Input Capacitance	C _{IN}					5	pF	
Internal Pull-up Resistors	R _{PU}			0.11	1.00	2.75	MΩ	
			GPIO1, GPIO2			2.2	kΩ	
Internal Pull-down Resistor	R _{PD}			0.11	1.00	2.80	MΩ	
Input Leakage Current	I _{IN(leak)}			V _{IN} = 1.8V or 0V	-10		+10	μA
Output Leakage Current	I _{OUT(leak)}			V _{OUT} = 1.8V or 0V	-10		+10	μA
Input Impedance	Z _{IN}		RF Input	f _{IN} = 1575.5MHz		50		Ω
Input Return Loss	R _{LIN}					-7		
Input Power Range	P _{IN}	GPS or GLONASS			-167			dBm
Input Frequency Range	f _{IN}				1560		1620	MHz
Operating Temperature	T _{AMB}			-40	+25	+85	°C	
Storage Temperature ⁵	T _{ST}			-55	+25	+125	°C	
Relative Humidity ⁶	R _H		T _{AMB}	5		95	%	

TABLE 4 – RECOMMENDED OPERATING CONDITIONS

Notes:

1. Typical values under radiated signal conditions of -130dBm and ambient temperature of +25°C.
2. ATP™ mode 200:1 (200ms on-time, 1s period), R01 standard ordering option, GPS-only tracking.
3. Transitional states of ATP™ power saving mode.
4. PTF™ mode 30:30 (30s max. on-time – 18s typical, 30m period), R01 standard ordering option, GPS-only tracking.
5. Longer TTF is expected while operating below -30°C to -40°C.
6. Relative Humidity is within Operating Temperature range.



14. PERFORMANCE

14.1. ACQUISITION TIME

TTF (Time To First Fix) – is the period of time from module’s power-up till valid position estimation.

14.1.1. HOT START

Hot Start results either from a software reset after a period of continuous navigation or a return from a short idle period that was preceded by a period of continuous navigation. During Hot Start all critical data (position, velocity, time, and satellite ephemeris) is valid to the specified accuracy and available in RAM.

14.1.2. SIGNAL REACQUISITION

Reacquisition follows temporary blocking of GNSS signals. Typical reacquisition scenario includes driving through tunnel.

14.1.3. AIDED START

Aided Start is a method of effectively reducing TTF by providing valid satellite ephemeris data. Aiding can be implemented using Ephemeris Push™, CGEE™ or SGEE™.

14.1.4. WARM START

Warm Start typically results from user-supplied position and time initialization data or continuous RTC operation with an accurate last known position available in RAM. In this state position and time data are present and valid, but satellite ephemeris data validity has expired.

14.1.5. COLD START

Cold Start occurs when satellite ephemeris data, position and time data are unknown. Typical Cold Start scenario includes first power application.

OPERATION ¹	MODE	VALUE	UNIT
Hot Start		< 1	s
Aided Start		< 10	s
Warm Start	GPS + GLONASS	< 26	s
	GPS	< 32	s
Cold Start	GPS + GLONASS	< 27	s
	GPS	< 35	s
Signal Reacquisition ²		< 1	s

TABLE 5 – ACQUISITION TIME

Notes:

1. EVK is 24-hrs. static under signal conditions of -130dBm and ambient temperature of +25°C.
2. Outage duration ≤ 30s.



14.2. SENSITIVITY

14.2.1. TRACKING

Tracking is an ability of receiver to maintain valid satellite ephemeris data. During tracking receiver may stop output valid position solutions. Tracking sensitivity defined as minimum GNSS signal power required for tracking.

14.2.2. REACQUISITION

Reacquisition follows temporary blocking of GNSS signals. Reacquisition sensitivity defined as minimum GNSS signal power required for reacquisition.

14.2.3. NAVIGATION

During navigation receiver consequently outputs valid position solutions. Navigation sensitivity defined as minimum GNSS signal power required for reliable navigation.

14.2.4. HOT START

Hot Start sensitivity defined as minimum GNSS signal power required for valid position solution under Hot Start conditions.

14.2.5. AIDED START

Aided Start sensitivity defined as minimum GNSS signal power required for valid position solution following aiding process.

14.2.6. COLD START

Cold Start sensitivity defined as minimum GNSS signal power required for valid position solution under Cold Start conditions, sometimes referred as ephemeris decode threshold.

OPERATION ¹	MODE	VALUE	UNIT
Tracking	GPS	-167	dBm
	GLONASS	-165	dBm
Navigation	GPS	-164	dBm
	GLONASS	-164	dBm
Reacquisition ²		-162	dBm
Hot Start ³		-160	dBm
Aided Start ⁴		-156	dBm
Cold Start	GPS	-148	dBm

TABLE 6 – SENSITIVITY



14.3. RECEIVED SIGNAL STRENGTH

PARAMETER ⁵	VALUE	UNIT
C/N ₀	45	dB-Hz

TABLE 7 – RECEIVED SIGNAL STRENGTH

Notes:

1. EVK is static, ambient temperature is +25°C
2. Outage duration ≤ 30s.
3. Hibernate state duration ≤ 5m.
4. Aiding using Broadcast Ephemeris (Ephemeris Push™) or Extended Ephemeris (CGEE™ or SGEE™).
5. Average C/N₀ reported for 4 SVs, EVK is 24-hrs. static, outdoor, ambient temperature is +25°C.

14.4. POWER CONSUMPTION

OPERATION ¹	MODE	VALUE	UNIT
Acquisition	GPS	82	mW
	GPS + GLONASS	100	mW
Tracking	GPS	72	mW
	GPS + GLONASS	92	mW
Low Power Tracking	ATP™ Tracking ²	14	mW
	PTF™ ³	0.8	
	5m Hibernate: 10s tracking	4	mW
Hibernate		60	μW

TABLE 8 – POWER CONSUMPTION

Notes:

1. Typical values under radiated signal conditions of -130dBm and ambient temperature of +25°C. Measured Vcc = 1.8V
2. ATP™ mode 100:1 (100ms on-time, 1s period), GPS-only tracking.
3. PTF™ mode 30:30 (30s max. on-time – 18s typical, 30m period), GPS-only tracking.



14.5. ACCURACY

PARAMETER		FORMAT	MODE	VALUE	UNIT
Position ¹	Horizontal	CEP (50%)	GPS + GLONASS	< 1.5	m
			GPS + SBAS	< 2.0	m
			GPS	< 2.5	m
		2dRMS (95%)	GPS + GLONASS	< 3.0	m
			GPS + SBAS	< 4.0	m
			GPS	< 5.0	m
	Vertical	VEP (50%)	GPS + GLONASS	< 2.5	m
			GPS + SBAS	< 3.5	m
			GPS	< 4.0	m
		2dRMS (95%)	GPS + GLONASS	< 5.0	m
GPS + SBAS			< 6.5	m	
GPS			< 7.5	m	
Velocity ²	over ground	50% of samples		< 0.01	m/s
Heading	to north	50% of samples		< 0.01	°
Time ¹		RMS jitter	1 PPS	≤ 30	ns

TABLE 9 – ACCURACY

Notes:

1. Module is static under signal conditions of -130dBm, ambient temperature is +25°C.
2. Speed over ground ≤ 30m/s.

14.6. DYNAMIC CONSTRAINS

PARAMETER	Metric	Imperial
Velocity and Altitude ¹	515m/s and 18,288m	1,000knots and 60,000ft
Velocity	600m/s	1,166knots
Altitude	-500m to 24,000m	-1,640ft to 78,734ft
Acceleration	4g	
Jerk	5m/s ³	

TABLE 10 – DYNAMIC CONSTRAINS

Note:

1. Standard dynamic constrains according to regulatory limitations.



15. POWER MANAGEMENT

15.1. POWER STATES

15.1.1. FULL POWER ACQUISITION

ORG1510 module stays in Full Power Acquisition state until a reliable position solution is made. Switching to GPS-only mode turns off GLONASS RF block lowering power consumption.

15.1.2. FULL POWER TRACKING

Full Power Tracking state is entered after a reliable position solution is achieved. During this state the processing is less intense compared to Full Power Acquisition, therefore power consumption is lower. Full Power Tracking state with navigation update rate at 5Hz consumes more power compared to default 1Hz navigation.

15.1.3. CPU ONLY

CPU Only is the transitional state of ATP™ power saving mode when the RF and DSP sections are partially powered off. This state is entered when the satellites measurements have been acquired, but navigation solution still needs to be computed.

15.1.4. STANDBY

Standby is the transitional state of ATP™ power saving mode when RF and DSP sections are completely powered off and baseband clock is stopped.

15.1.5. HIBERNATE

ORG1510 module boots into Hibernate state after power supply applied.

During this state RF, DSP and baseband sections are completely powered off leaving only RTC and Battery-Backed RAM running.

ORG1510 will perform Hot Start if stayed in Hibernate state less than 4 hours from last valid position solution.

15.2. BASIC POWER SAVING MODE

Basic power saving mode is elaborating host in straightforward way for controlling transfers between Full Power and Hibernate states.

Current profile of this mode has no hidden cycles of satellite data refresh.

Host may condition transfers by tracking duration, accuracy, satellites in-view or other parameters.

15.3. SELF MANAGED POWER SAVING MODES

Multi Micro Hornet module has several self-managed power saving modes tailored for different use cases.

These modes provide several levels of power saving with degradation level of position accuracy. Initial operation in Full Power state is a prerequisite for accumulation of satellite data determining location, fine time and calibration of reference clocks.

15.3.1. ADAPTIVE TRICKLE POWER (ATP™)

ATP™ is best suited for applications that require navigation solutions at a fixed rate as well as low power consumption and an ability to track weak signals.

This power saving mode provides the most accurate position among self-managed modes. In this mode the module is intelligently cycled between Full Power state, CPU Only state consuming 14mA and Standby state consuming $\leq 100\mu A$, therefore optimizing current profile for low power operation.

ATP™ period that equals navigation solution update can be 1 second to 10 seconds. On-time including Full Power Tracking and CPU Only states can be 200ms to 900ms.

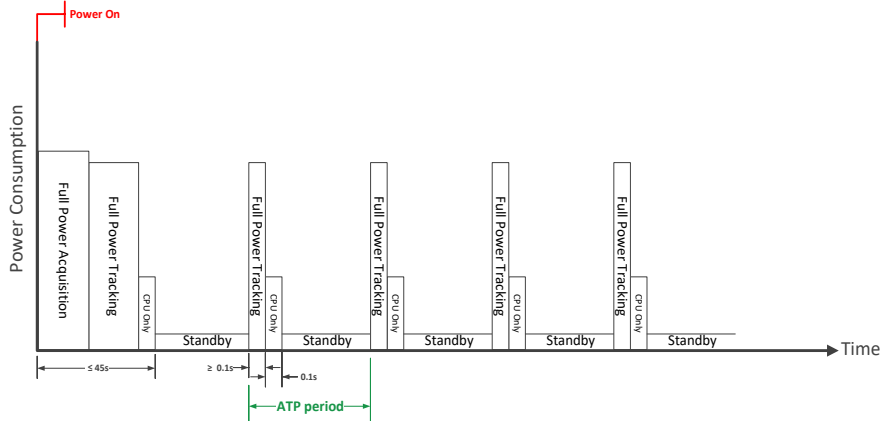

FIGURE 3 – ATP™ TIMING

15.3.2. PUSH TO FIX (PTF™)

PTF™ is best suited for applications that require infrequent navigation solutions.

In this mode ORG1510 module is mostly in Hibernate state, drawing $\leq 54\mu A$ of current, waking up for satellite data refresh in fixed periods of time.

PTF™ period can be anywhere between 10 seconds and 2 hours.

Host can initiate an instant position report by toggle the ON_OFF pad to wake up the module. During fix trial module will stay in Full Power state until good position solution is estimated or pre-configured timeout for it has expired.

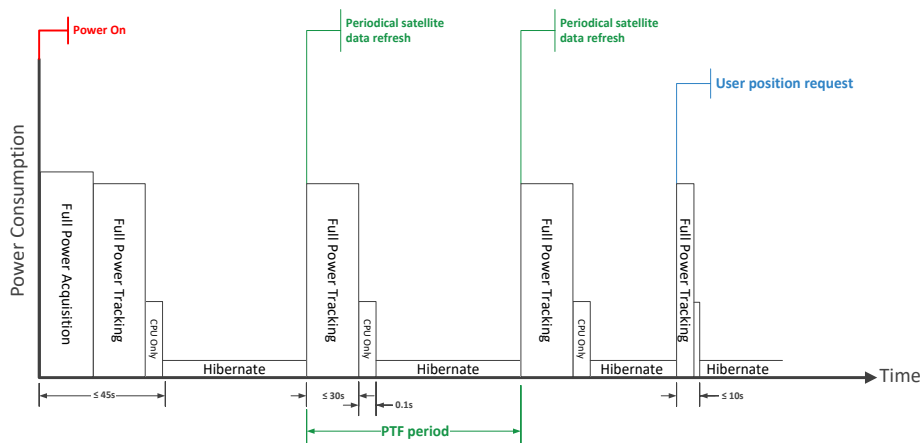

FIGURE 4 – PTF™ TIMING

15.3.3. ADVANCED POWER MANAGEMENT (APM™)

APM™ mode is designed for Aided-GPS wireless applications.

APM™ allows power savings while ensuring that the **Quality of the Solution (QoS)** is maintained when signals level drop.

In APM™ mode the module is intelligently cycled between Full Power and Hibernate states. In addition to setting the position report interval, a QoS specification is available that sets allowable error estimates and selects priorities between position report interval and more power saving.

User may select between Duty Cycle Priority for more power saving and Time Between Fixes (TBF) priority with defined or undefined maximum horizontal error.

TBF range is from 10s to 180s between fixes, Power Duty Cycle range is between 5% to 100%.

Maximum position error is configurable between 1 to 160m.

The number of APM™ fixes is configurable up to 255 or set to continuous.

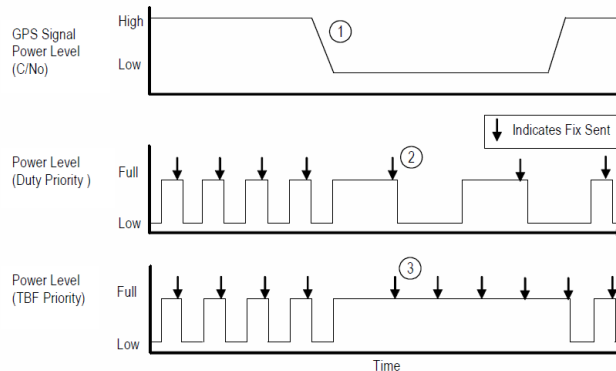

FIGURE 5 – APM™ TIMING

Notes:

1. GPS signal level drops (e.g. user walks indoor).
2. Lower signal results in longer ON time. To maintain Duty Cycle Priority, OFF time is increased.
3. Lower signal means missed fix. To maintain future TBFs module goes Full Power state until signal levels improve.



16. EXTENDED FEATURES

16.1. ALMANAC BASED POSITIONING (ABP™)

With ABP™ mode enabled, the user can get shorter Cold Start TTFF as tradeoff with position accuracy. The reported position in this case is an indication only – hundreds of meters circular error probability. It is not recommended to use ABP™ in applications which demand precise position.

When no sufficient ephemeris data is available to calculate an accurate solution, a coarse solution will be provided where the position is calculated based on one or more of the GPS satellites, having their states derived from the almanac data.

Data source for ABP™ may be either stored factory almanac, broadcasted or pushed almanac.

16.2. ACTIVE JAMMER DETECTOR AND REMOVER

Jamming Detector is embedded DSP software block that detects interference signals in GPS L1 and GLONASS L1 band.

Jamming Remover is additional DPS software block that sort-out Jamming Detector output mitigating up to 8 interference signals of Continuous Wave (CW) type up to 80dB-Hz each.

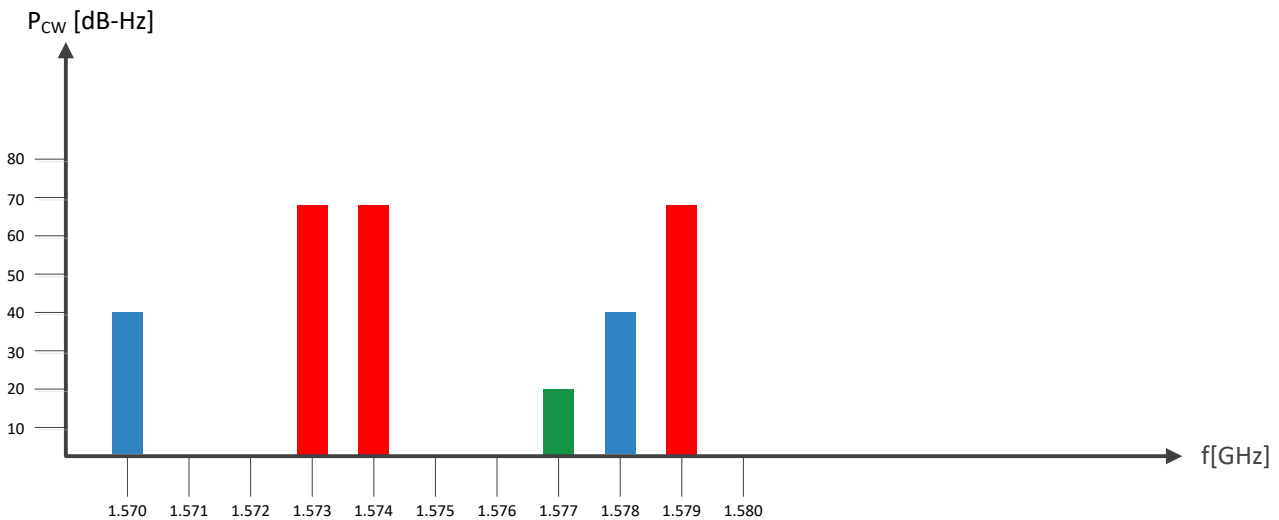

FIGURE 6 – ACTIVE JAMMER DETECTOR FREQUENCY PLOT

16.3. CLIENT GENERATED EXTENDED EPHEMERIS (CGEE™)

CGEE™ feature allows shorter TTFFs by providing predicted (synthetic) ephemeris files created within a non-networked host system from previously received satellite ephemeris data.

The prediction process requires good receipt of broadcast ephemeris data for all satellites.

EE files created this way are good for up to 3 days and then expire.

CGEE™ feature requires avoidance of power supply removal.

CGEE™ data files are stored and managed by host.

16.4. SERVER GENERATED EXTENDED EPHEMERIS (SGEE™)

SGEE™ enables shorter TTFFs by fetching Extended Ephemeris (EE) file downloaded from web server. Host is initiating periodic network sessions of EE file downloads, storage and provision to module.

There is one-time charge for set-up, access to OriginGPS EE distribution server and end-end testing for re-distribution purposes, or there is a per-unit charge for each module within direct SGEE™ deployment.

GPS EE files are provided with look-ahead of 1, 3, 7, 14 or 31 days.

GLONASS EE files are provided with look-ahead of 1, 3, 7 or 14 days.



17. INTERFACE

17.1. PAD ASSIGNMENT

PAD	NAME	FUNCTION			DIRECTION	FULL POWER ¹	HIBERNATE ²
1	ON_OFF	Power State Control			Input	Hi-Z	Hi-Z
2	1PPS	UTC Time Mark			Output	Low	Low
3	TX	UART Transmit	SPI Data Out	I ² C Clock	Bi-directional	High	Hi-Z
4	V _{cc}	System Power			Power		
5	GND	System Ground			Power		
6	WAKEUP	Power Status			Output	High	Low
7	$\overline{\text{CTS}}$	Interface Select 1	UART Clear To Send	SPI Clock	Bi-directional	Low	Low
8	$\overline{\text{RESET}}$	Asynchronous Reset			Input	High	High
9	$\overline{\text{RTS}}$	Interface Select 2	UART Ready To Send	SPI Chip Select	Bi-directional	High	High
10	RX	UART Receive	SPI Data In	I ² C Data	Bi-directional	High	High

TABLE 11 – PIN-OUT

BOTTOM VIEW

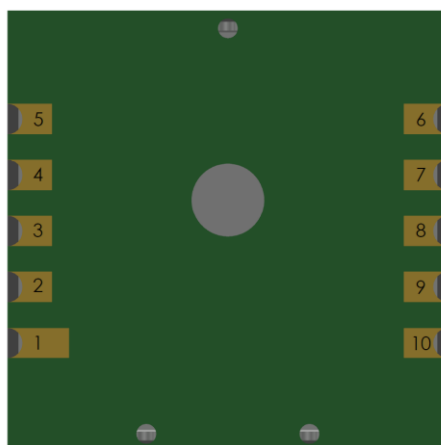

FIGURE 7 – PAD ASSIGNMENT

Notes:

1. Full Power Acquisition, Full Power Tracking and CPU Only states.
2. Hibernate and Standby states.

17.2. POWER SUPPLY

It is recommended to keep the power supply on all the time in order to maintain RTC block active and keep satellite data in RAM for fastest possible TTFF. When V_{CC} is removed settings are reset to factory default and the receiver performs Cold Start on next power up.

17.2.1. $V_{CC} = 1.8V$

V_{CC} is $1.8V \pm 5\%$ DC and must be provided from regulated power supply.

Inrush current is up to 300mA for about $20\mu s$ duration, V_{CC} can be dropped down to 1.7V.

Typical I_{CC} during acquisition is 55mA. Lower acquisition current is possible disabling GLONASS radio path by software command.

During tracking the processing is less intense compared to acquisition, therefore power consumption is lower.

Maximum I_{CC} current in Hibernate state is $54\mu A$, while all I/O lines externally held in Hi-Z state.

Output capacitors are critical when powering ORG1510 from switch-mode power supply.

Filtering is important to manage high alternating current flows on the power input connection.

An additional LC filter on ORG1510 power input may be needed to reduce system noise.

The high rate of ORG1510 input current change requires low ESR bypass capacitors.

Additional higher ESR output capacitors can provide input stability damping.

The ESR and size of the output capacitors directly define the output ripple voltage with a given inductor size. Large low ESR output capacitors are beneficial for low noise.

Voltage ripple below $50mV_{pp}$ allowed for frequencies between 100KHz to 1MHz.

Voltage ripple below $15mV_{pp}$ allowed for frequencies above 1MHz.

Higher voltage ripple may compromise ORG1510 performance.

17.2.2. GROUND

Ground pad must be connected to host PCB Ground with shortest possible trace or by multiple vias.

17.3. CONTROL INTERFACE

17.3.1. ON_OFF

ON_OFF input is used to switch module between different power states:

- + While in Hibernate state, ON_OFF pulse will initiate transfer into Full Power state.
- + While in ATP™ mode, ON_OFF pulse will initiate transfer into Full Power state.
- + While in PTF™ mode, ON_OFF pulse will initiate one PTF™ request.
- + While in Full Power state, ON_OFF pulse will initiate orderly shutdown into Hibernate state.

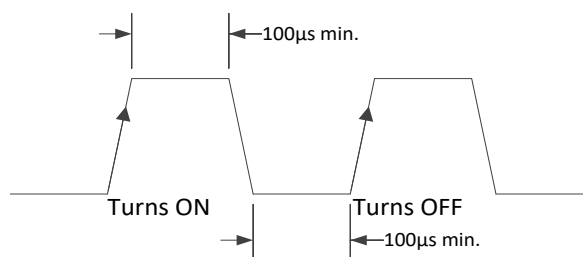

FIGURE 8 – ON_OFF TIMING

ON_OFF detector set requires a rising edge and high logic level that persists for at least $100\mu s$.

ON_OFF detector reset requires ON_OFF asserted to low logic level for at least $100\mu s$.

Recommended ON_OFF Low-High-Low pulse length is 100ms.

ON_OFF pulses with less than 1s intervals are not recommended.

Multiple switch bounce pulses are recommended to be filtered out.

Pull-down resistor of $10k\Omega$ - $33k\Omega$ is recommended to avoid accidental power mode change.

ON_OFF input is tolerable up to 3.6V.

Do not drive high permanently or pull-up this input.

This line must be connected to host.

17.3.2. WAKEUP

WAKEUP output from module is used to indicate power state.

A low logic level indicates that the module is in one of its low-power states - Hibernate or Standby. A high logic level indicates that the module is in Full Power state.

Connecting WAKEUP to ON_OFF enables autonomous start to Full Power state.

In addition WAKEUP output can be used to control auxiliary devices.

Wakeup output is LVCMOS 1.8V compatible.

Do not connect if not in use.

17.3.3. $\overline{\text{RESET}}$

Power-on-Reset (POR) sequence is generated internally.

In addition, external reset is available through $\overline{\text{RESET}}$ pad.

Resetting module clears the state machine of self-managed power saving modes to default.

$\overline{\text{RESET}}$ signal should be applied for at least 1 μ s.

$\overline{\text{RESET}}$ input is active low and has internal pull-up resistor of 1M Ω .

Do not drive this input high.

Do not connect if not in use.

17.3.4. 1PPS

Pulse-Per-Second (PPS) output provides a pulse signal for timing purposes.

PPS output starts when 3D position solution has been obtained using 5 or more GNSS satellites.

PPS output stops when 3D position solution is lost.

Pulse length (high state) is 200ms with rising edge is less than 30ns synchronized to UTC epoch.

The correspondent UTC time message is generated and put into output FIFO 300ms after the PPS signal. The exact time between PPS and UTC time message delivery depends on message rate, message queue and communication baud rate.

1PPS output is LVCMOS 1.8V compatible.

Do not connect if not in use.



17.4. DATA INTERFACE

ORG1510 module has 3 types of interface ports to connect to host - UART, SPI or I²C – all multiplexed on a shared set of pads. At system reset host port interface lines are disabled, so no conflict occurs. Logic values on \overline{CTS} and \overline{RTS} are read by the module during startup and define host port type. External resistor of 10k Ω is recommended. Pull-up resistor is referenced to 1.8V.

PORT TYPE	\overline{CTS}	\overline{RTS}
UART	External pull-up	Don't install an external pull up
SPI (default)	Don't install an external pull up	Don't install an external pull up
I ² C	Don't install an external pull up	External pull-down

TABLE 12 – HOST INTERFACE SELECT

17.4.1. UART

Multi Micro Hornet ORG1510 has a standard UART port:

- + TX used for GPS data reports. Output logic high voltage level is LVCMOS 1.8V compatible.
- + RX used for receiver control. Input logic high voltage level is 1.45V, tolerable up to 3.6V.
- + UART flow control using \overline{CTS} and \overline{RTS} lines is disabled by default.
Can be turned on by sending OSP® Message ID 178, Sub ID 70 input command.

17.4.2. SPI

SPI host interface features are:

- + Slave SPI Mode 1, supports clock up to 6.8MHz.
- + RX and TX have independent 2-byte idle patterns of '0xA7 0xB4'.
- + TX and RX each have independent 1024 byte FIFO buffers.
- + TX FIFO is disabled when empty and transmits its idle pattern until re-enabled.
- + RX FIFO detects a software specified number of idle pattern repeats and then disables FIFO input until the idle pattern is broken.
- + FIFO buffers can generate an interrupt at any fill level.
- + SPI detects synchronization errors and can be reset by software.
- + Output is LVCMOS 1.8V compatible. Inputs are tolerable up to 3.6V.

17.4.3. I²C

I²C host interface features are:

- + I²C Multi-Master Mode - module initiates clock and data, operating speed 400kbps.
- + I²C address '0x60' for RX and '0x62' for TX.
- + Individual transmit and receive FIFO length of 64 bytes.
- + Clock rate can be switched 100KHz (default 400KHz), address can be changed (default 0x62 for TX FIFO and 0x60 for RX FIFO) by sending OSP Message ID 178, Sub ID 70 input command.
- + SCL and SDA are pseudo open-drain lines, therefore require external pull-up resistors of 2.2k Ω to 1.8V, or 3.3k Ω to 3.3V.
- + Please look on the I2C Appendix on the last page on this data sheet.

18. TYPICAL APPLICATION CIRCUIT

UART: R1=10K; R2, R5, R6 - DO NOT ASSEMBLE. Use level shifter if MCU_IO level >1.8V
SPI: R1, R2, R5, R6 - DO NOT ASSEMBLE
I2C: R2=10K; R5, R6=2.2K; R1 - DO NOT ASSEMBLE

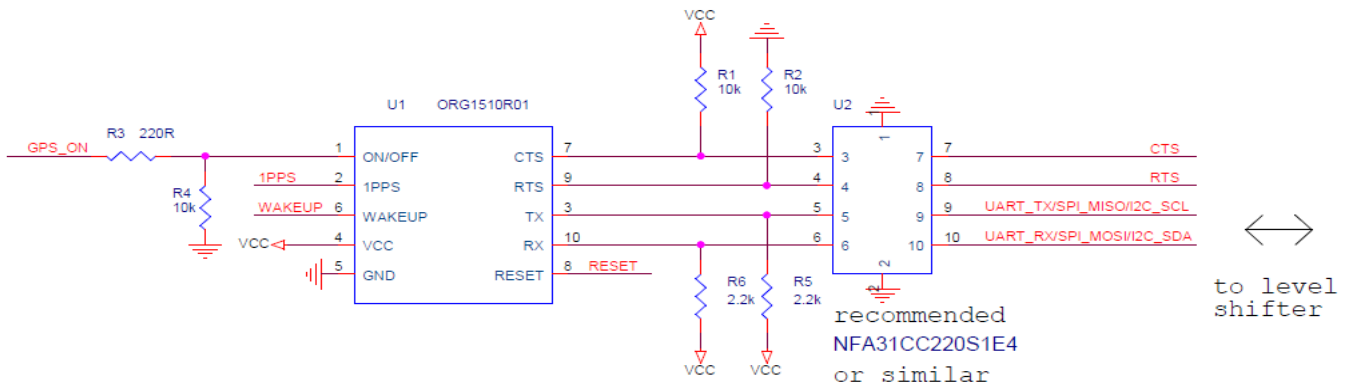

FIGURE 9 – REFERENCE SCHEMATIC DIAGRAM, UART

19. RECOMMENDED PCB LAYOUT

Please refer to the Application Note in the following link:

<https://origingps.com/gnss-modules/gnss-resources/>

Scroll down and click “Hornet Modules Layout Recommendations and Integration – Application Note”.

20. DESIGN CONSIDERATIONS

ORG1510 incorporates on-board antenna element that is perfectly matched to receiver front-end, frequency trimmed to GPS band and Right-Hand Circularly Polarized (RHCP).

OriginGPS proprietary module structure is providing stable resonance of antenna in GPS band with very low dependence on host PCB size, it’s conducting planes geometry and stack-up.

To prevent PCB factor on antenna resonance avoid copper pouring on module side.

To prevent module orientation from causing polarization losses in on-board antenna avoid long and narrow copper planes beneath.

ORG1510 operates with received signal levels down to -167dBm and can be affected by high absolute levels of RF signals out of GNSS band, moderate levels of RF interference near GNSS band and by low-levels of RF noise in GNSS band.

RF interference from nearby electronic circuits or radio transmitters can contain enough energy to desensitize ORG1510. These systems may also produce levels of energy outside of GNSS band, high enough to leak through RF filters and degrade the operation of the radios in ORG1510.

This issue becomes more critical in small products, where there are industrial design constraints.

In that environment, transmitters for Wi-Fi, Bluetooth, RFID, cellular and other radios may have antennas physically close to ORG1510.

To prevent degraded performance of ORG1510, OriginGPS recommends performing EMI/jamming susceptibility tests for radiated and conducted noise on prototypes and assessing risks of other factors.

Contact OriginGPS for application specific recommendations and design review services.



21. OPERATION

When power is first applied, module goes into a Hibernate state while integrated RTC starts and internal Finite State Machine (FSM) sequences through to “Ready-to-Start” state.

Host is not required to control external master $\overline{\text{RESET}}$ since module’s internal reset circuitry handles detection of power application.

While in “Ready-to-Start” state, module awaits a pulse to the ON_OFF input.

Since integrated RTC startup times are variable, host is required either to wait for a fixed interval or to monitor a short Low-High-Low pulse on WAKEUP output that indicates FSM “Ready-to-Start” state.

Another option is to repeat a pulse on the ON_OFF input every second until the module starts by either detecting a stable logic high level on WAKEUP output or neither generation of UART messages.

21.1. STARTING THE MODULE

A pulse on the ON_OFF input line when FSM is ready and in startup-ready state, Hibernate state, standby state, will command the module to start.

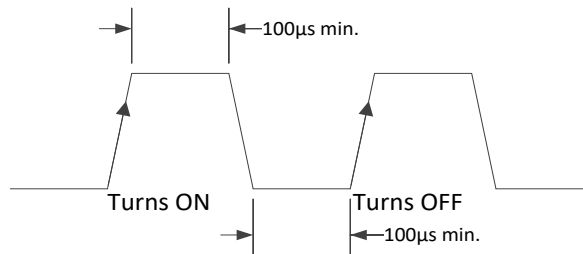

FIGURE 10 – ON_OFF TIMING

ON_OFF detector set requires a rising edge and high logic level that persists for at least 100µs.

ON_OFF detector reset requires ON_OFF asserted to low logic level for at least 100µs.

Recommended ON_OFF Low-High-Low pulse length is 100ms.

ON_OFF pulses with less than 1s intervals are not recommended.

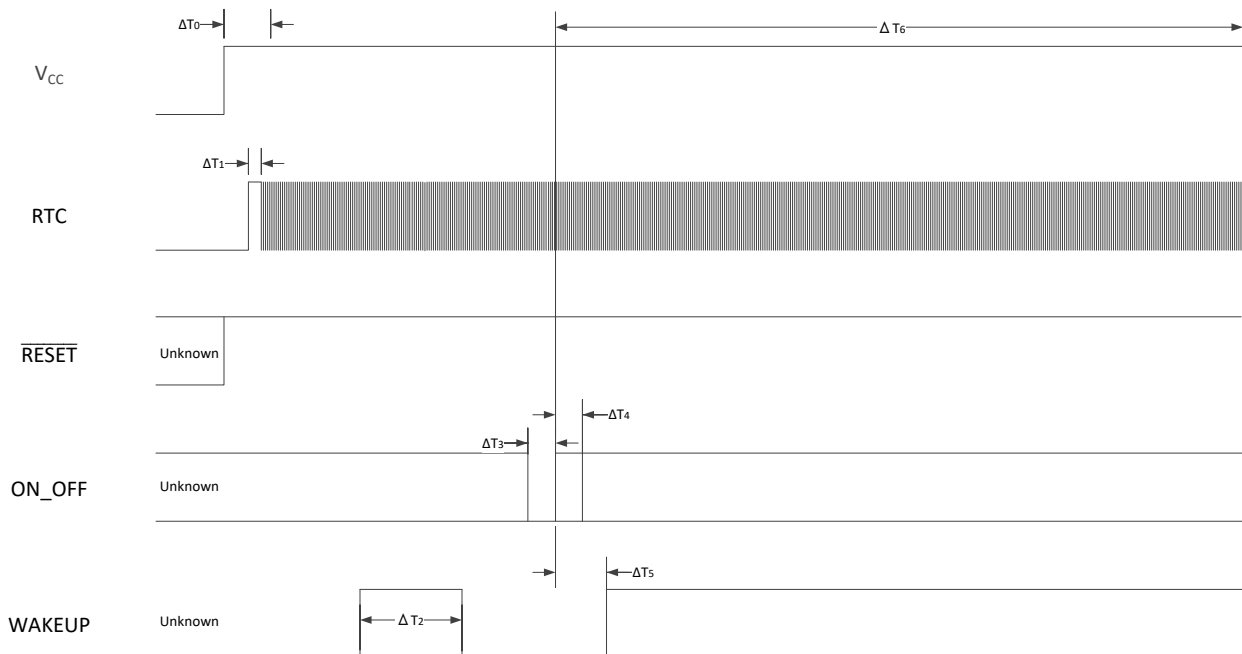

FIGURE 10 – START-UP TIMING



SYMBOL	PARAMETER	CONDITION	MIN	TYP	MAX	UNIT
f_{RTC}	RTC Frequency	+25°C	-20 ppm	32768	+20 ppm	Hz
t_{RTC}	RTC Tick	+25°C		30.5176		μ s
ΔT_1	RTC Startup Time			300		ms
ΔT_0	Power Stabilization		$6 \cdot t_{RTC} + \Delta T_1$	$7 \cdot t_{RTC} + \Delta T_1$	$8 \cdot t_{RTC} + \Delta T_1$	μ s
ΔT_2	WAKEUP Pulse	RTC running		10		t_{RTC}
ΔT_3	ON_OFF Low		3			t_{RTC}
ΔT_4	ON_OFF High		3			t_{RTC}
ΔT_5	ON_OFF to WAKEUP high	After ON_OFF		6		t_{RTC}
ΔT_6	ON_OFF to ARM boot	After ON_OFF		2130		t_{RTC}

TABLE 13 – START-UP TIMING

21.2. AUTONOMOUS POWER ON

Connecting WAKEUP output (pad 6) to ON_OFF input (pad 1) enables self-start to Full Power state from Ready-To-Start state following boot process.

When host data interface is set UART, module will start autonomously transmitting NMEA messages after first power supply application. Further transfers between Full Power and Hibernate states require additional logic circuitry combined with serial command.

21.3. VERIFYING THE MODULE HAS STARTED

WAKEUP output will go high indicating module has started.

System activity indication depends upon selected serial interface.

The first message to come out of module is "OK_TO_SEND" - '\$PSRF150,1*3E'.

21.3.1. UART

When active, the module will output NMEA messages at the 4800bps.

21.3.2. I²C

In Multi-Master mode with no bus contention - the module will spontaneously send messages.

In Multi-Master mode with bus contention - the module will send messages after the I²C bus contention resolution process allows it to send.

21.3.3. SPI

Since module is SPI slave device, there is no possible indication of system "ready" through SPI interface. Host must initiate SPI connection approximately 1s after WAKEUP output goes high.

21.4. CHANGING PROTOCOL AND BAUD RATE¹

Protocol and baud rate can be changed by NMEA \$PSRF100 serial message.

21.5. CHANGING SATELLITE CONSTELLATION¹

Satellite constellations used in position solution can be changed by OSP[®] Message ID 222 Sub ID 16.

21.6. SHUTTING DOWN THE MODULE

Transferring module from Full Power state to Hibernate state can be initiated in two ways:

- + By a pulse on ON_OFF input.
- + By NMEA (\$PSRF117) or OSP (MID205) serial message.

Orderly shutdown process may take anywhere from 10ms to 900ms to complete, depending upon operation in progress and messages pending, and hence is dependent upon serial interface speed and controls. Module will stay in Full Power state until TX FIFO buffer is emptied.

The last message during shutdown sequence is '\$PSRF150,0*3F'.

Note:

1. Changes to default firmware settings are volatile and will be discarded at power re-cycle.



22. FIRMWARE

22.1. DEFAULT SETTINGS

Power On State		Hibernate
Default Interface ¹		SPI
SPI Data Format		NMEA
UART Settings		4,800bps.
UART Data Format		NMEA
I ² C Settings		Multi-Master 400kbps
I ² C Data Format		NMEA
Satellite Constellation		GPS + GLONASS
NMEA Messages		\$GPGGA @1 sec.
		\$GNGNS @ 1 sec.
		\$GNGSA @ 1 sec.
		\$GPGSV @ 5 sec.
		\$GLGSV @ 5 sec.
		\$GNRMC @ 1 sec.
Firmware Defaults	SBAS	OFF
	ABP™	OFF
	Static Navigation	ON
	Track Smoothing	OFF
	Jammer Detector	ON
	Jammer Remover	OFF
	Fast Time Sync	OFF
	Pseudo DR Mode	ON
	Power Saving Mode	OFF
	3SV Solution Mode	ON
	MEMS Gateway	OFF
	Data Logger	OFF
	5Hz Update Rate	OFF

TABLE 14 – DEFAULT FIRMWARE SETTINGS

Note:

1. Without external resistor straps on \overline{CTS} or \overline{RTS} .

22.2. FIRMWARE UPDATES

Firmware updates can be considered exclusively as patches on top of baseline ROM firmware. Those patch updates may be provided by OriginGPS to address ROM firmware issues as a method of performance improvement. Typical patch file size is 24KB.

Host controller is initiating load and application of patch update by communicating module's Patch Manager software block allocating 16KB of memory space for patch and additional 8KB for cache.

Patch updates are preserved until RAM is discarded.

Since this is a ROM-based unit, the firmware patch should be uploaded after every power cycle.

Upgrading the Patch is mandatory for stable operation.

23. HANDLING INFORMATION

23.1. MOISTURE SENSITIVITY

ORG1510 modules are MSL 3 designated devices according to IPC/JEDEC J-STD-033B standard.

Module in sample or bulk package should be baked prior to assembly at 125°C for 48 hours.

23.2. ASSEMBLY

The module supports automatic pick-and-place assembly and reflow soldering processes.

Suggested solder paste stencil is 5 mil to ensure sufficient solder volume.

23.3. SOLDERING

Reflow soldering of the module always on component side (Top side) of the host PCB according to standard IPC/JEDEC J-STD-020D for LGA SMD.

Avoid exposure of ORG1510 to face-down reflow soldering process.

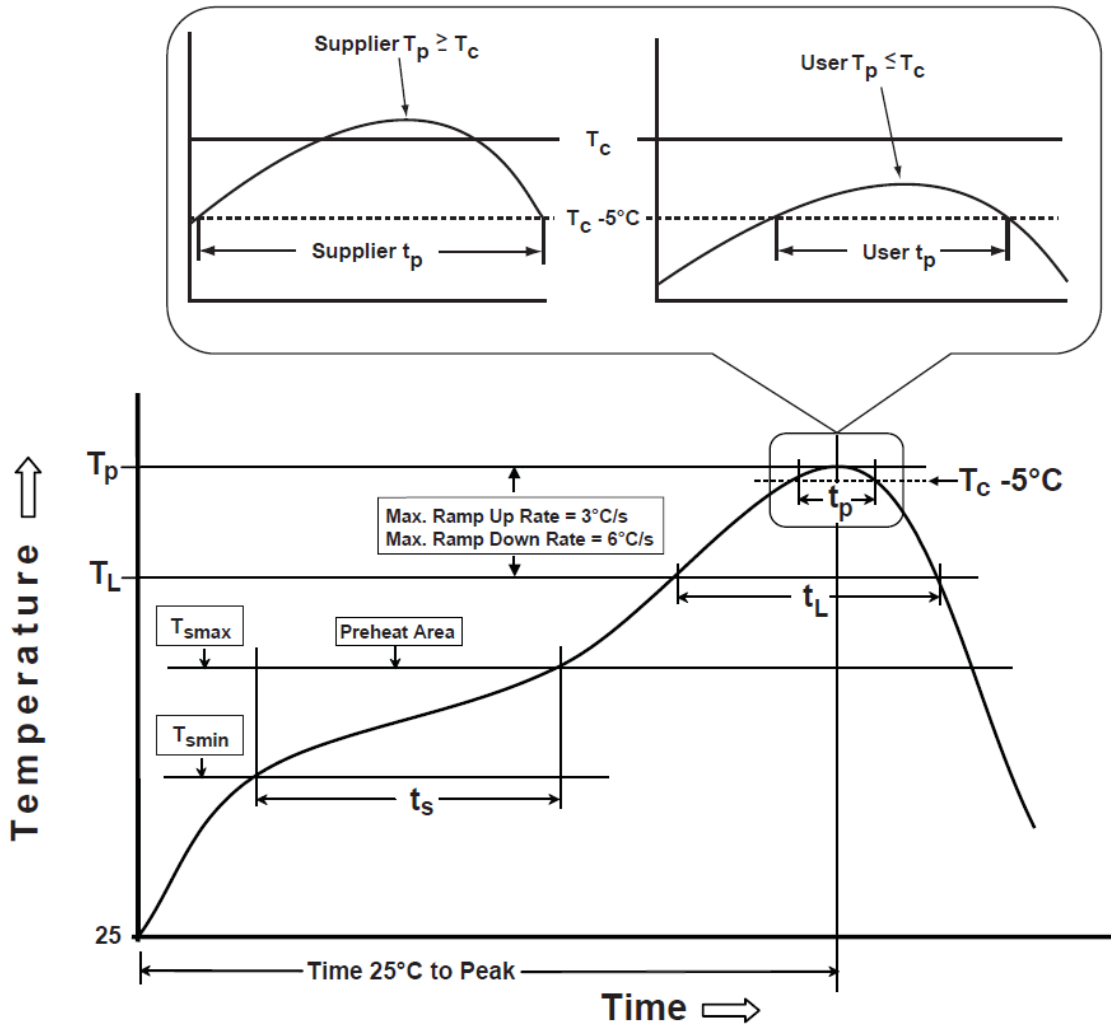

FIGURE 11 – RECOMMENDED SOLDERING PROFILE

Referred temperature is measured on top surface of the package during the entire soldering process. Suggested peak reflow temperature is 250°C for 30 sec. for Pb-Free solder paste. Actual board assembly reflow profile must be developed individually per furnace characteristics. Reflow furnace settings depend on the number of heating/cooling zones, type of solder paste/flux used, board design, component density and packages used.

SYMBOL	PARAMETER	MIN	TYP	MAX	UNIT
T_c	Classification Temperature		250		°C
T_p	Package Temperature			250	°C
T_L	Liquidous Temperature		217		°C
T_s	Soak/Preheat Temperature	150		200	°C
t_s	Soak/Preheat Time	60		120	s
t_L	Liquidous Time	60		150	s
t_p	Peak Time		30		s

TABLE 15 – SOLDERING PROFILE PARAMETERS

23.4. CLEANING

If flux cleaning is required, module is capable to withstand standard cleaning process in vapor degreaser with the Solvon® n-Propyl Bromide (NPB) solvent and/or washing in DI water.

Avoid cleaning process in ultrasonic degreaser, since specific vibrations may cause performance degradation or destruction of internal circuitry.

23.5. REWORK

If localized heating is required to rework or repair the module, precautionary methods are required to avoid exposure to solder reflow temperatures that can result in permanent damage to the device.

23.6. ESD SENSITIVITY

This product is ESD sensitive device and must be handled with care.



23.7. SAFETY INFORMATION

Improper handling and use can cause permanent damage to the product.

23.8. DISPOSAL INFORMATION

This product must not be treated as household waste.

For more detailed information about recycling electronic components contact your local waste management authority.



24. MECHANICAL SPECIFICATIONS

- + ORG1510 module has advanced ultra-miniature LGA SMD packaging sized 10mm x 10mm.
- + ORG1510 built on a PCB assembly enclosed with metallic RF shield box and antenna element on top of it.
- + There are 10 castellated LGA SMT pads made Cu base and ENIG plating on bottom side.

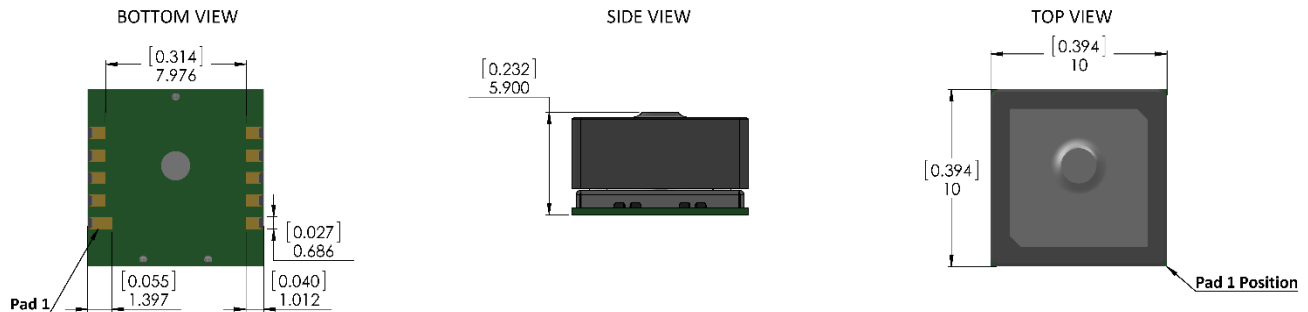

FIGURE 13 – MECHANICAL DRAWING

Dimensions	Length	Width	Height	Weight	
	mm	10.00 +0.20/ -0.10	10.00 +0.30/ -0.10	5.90 +0.30/ -0.10	g
inch	0.394 +0.008/ -0.004	0.394 +0.012/ -0.004	0.232 +0.012/ -0.004	oz	0.08

TABLE 16 – MECHANICAL SUMMARY

25. COMPLIANCE

The following standards are applied on the production of ORG1510 modules:

- + IPC-6011/6012 Class2 for PCB manufacturing
- + IPC-A-600 Class2 for PCB inspection
- + IPC-A-610D Class2 for SMT acceptability

ORG1510 modules are manufactured in ISO 9001:2008 accredited facilities.

ORG1510 modules are manufactured in ISO 14001:2004 accredited facilities.

ORG1510 modules are manufactured in OHSAS 18001:2007 accredited facilities.

ORG1510 modules are designed, manufactured and handled in compliance with the Directive 2011/65/EU of the European Parliament and of the Council of June 2011 on the Restriction of the use of certain Hazardous Substances in electrical and electronic equipment, referred as RoHS II.

ORG1510 modules are manufactured and handled in compliance with the applicable substance bans as of Annex XVII of Regulation 1907/2006/EC on Registration, Evaluation, Authorization and Restriction of Chemicals including all amendments and candidate list issued by ECHA, referred as REACH.

ORG1510 modules comply with the following EMC standards:

- + EU CE EN55022:06+A1(07), Class B
- + US FCC 47CFR Part 15:09, Subpart B, Class B
- + JAPAN VCCI V-3/2006.04





26. PACKAGING AND DELIVERY

26.1. APPEARANCE

ORG1510 modules are delivered in reeled tapes for automatic pick and place assembly process.

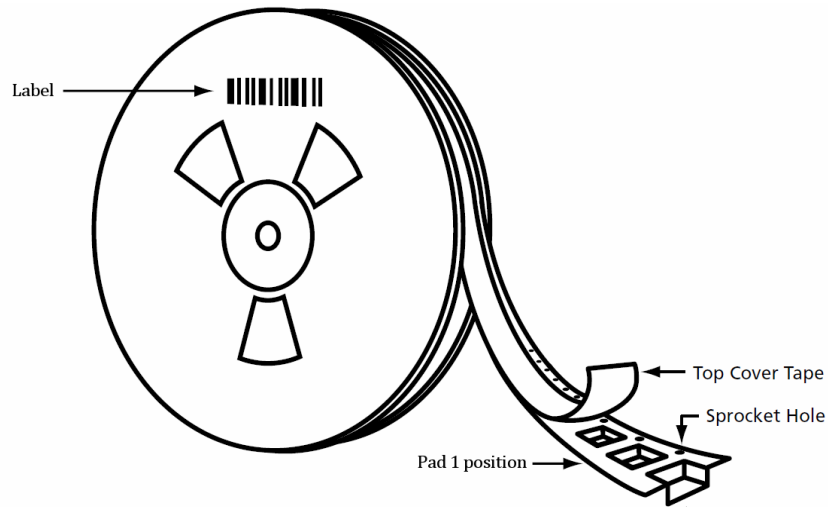

FIGURE 14 – MODULE POSITION

ORG1510 modules are packed in 2 different reel types.

SUFFIX	TR1	TR2
Quantity	150	500

TABLE 17 – REEL QUANTITY

Reels are dry packed with humidity indicator card and desiccant bag according to IPC/JEDEC J-STD-033B standard for MSL 3 devices.

Reels are vacuum sealed inside anti-static moisture barrier bags.

Sealed reels are labeled with MSD sticker providing information about:

- + MSL
- + Shelf life
- + Reflow soldering peak temperature
- + Seal date

Sealed reels are packed inside cartons.

Reels, reel packs and cartons are labeled with sticker providing information about:

- + Description
- + Part number
- + Lot number
- + Customer PO number
- + Quantity
- + Date code

26.2. CARRIER TAPE

Carrier tape material - polystyrene with carbon (PS+C).

Cover tape material – polyester based film with heat activated adhesive coating layer.

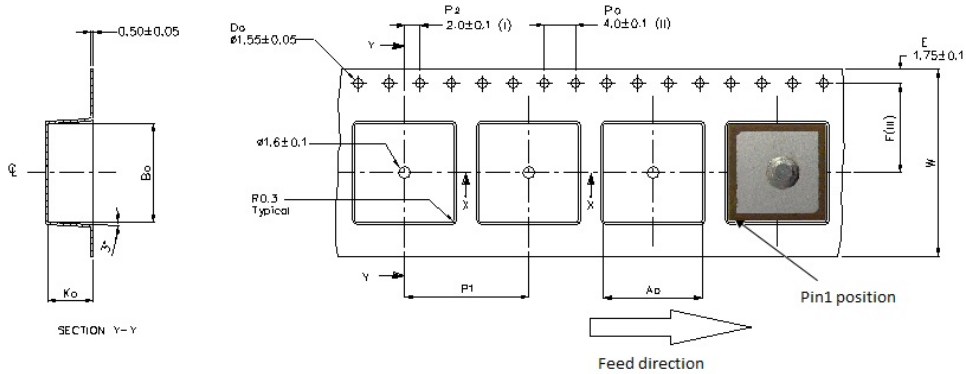

FIGURE 15 – CARRIER TAPE

	mm	inch
A ₀	10.9 ± 0.1	0.429 ± 0.004
B ₀	10.7 ± 0.1	0.421 ± 0.004
K ₀	6.1 ± 0.1	0.240 ± 0.004
F	7.5 ± 0.1	0.295 ± 0.004
P1	12.0 ± 0.1	0.472 ± 0.004
W	16.0 ± 0.3	0.630 ± 0.012

TABLE 18 – CARRIER TAPE DIMENSIONS

26.3. REEL

Reel material - antistatic plastic.

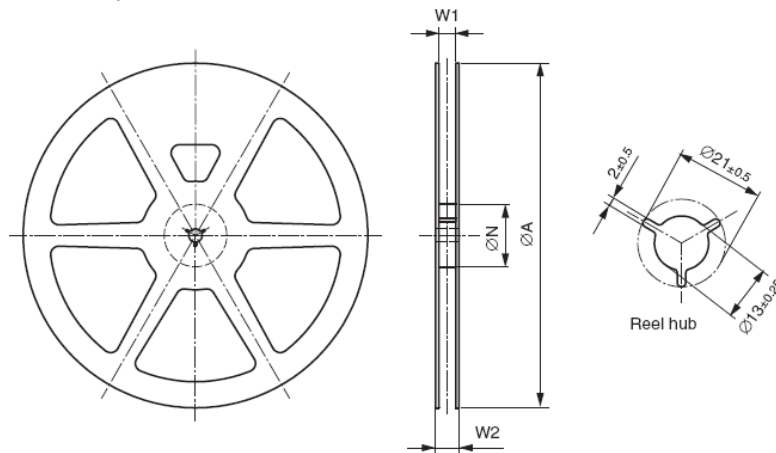

FIGURE 16 – REEL

SUFFIX	TR1		TR2	
	mm	inch	mm	inch
ØA	178.0 ± 1.0	7.00 ± 0.04	330.0 ± 2.0	13.00 ± 0.08
ØN	60.0 ± 1.0	2.36 ± 0.04	102.0 ± 2.0	4.02 ± 0.08
W1	16.7 ± 0.5	0.66 ± 0.02	16.7 ± 0.5	0.66 ± 0.02
W2	19.8 ± 0.5	0.78 ± 0.02	22.2 ± 0.5	0.87 ± 0.02

TABLE 19 – REEL DIMENSIONS

27. ORDERING INFORMATION

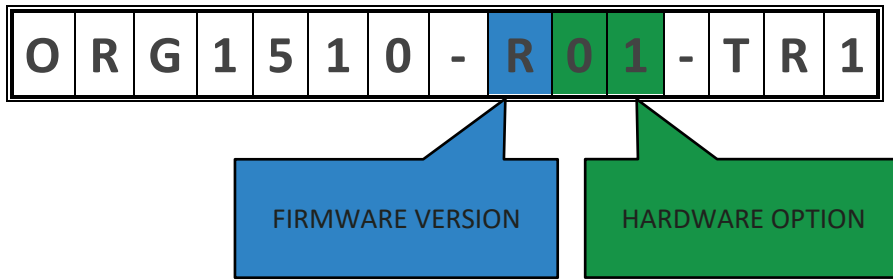

TABLE 20 – ORDERING OPTIONS

PART NUMBER	FW VERSION	HW OPTION	V _{CC} RANGE	PACKAGING	SPQ
ORG1510-R01-TR1	R	01	1.8V	REELED TAPE	150
ORG1510-R01-TR2	R	01	1.8V	REELED TAPE	500
ORG1510-R01-UAR	R	01	5V USB	EVALUATION KIT	1

TABLE 21 – ORDERABLE DEVICES



28. I2C APPENDIX

I²C host interface features are:

- + I²C Multi-Master mode - module initiates clock and data, default operating speed 400kbps.
- + I²C address '0x60' for commands from controller to GPS-module. (Default)
- + I²C address '0x62' for the data transmits from the GPS-module to the host. (Default)
- + Individual transmit and receive FIFO length of 64 bytes.
- + SCL and SDA are pseudo open-drain lines, therefore require external pull-up resistors of 2.2kΩ to 1.8V, or 3.3kΩ to 3.3V.
- + Multi-Master mode – the Host (MCU) can operate either in Slave mode or Multi-Master mode (more common). If MCU is acting as slave, then it can only listen to the GPS.
If you want to send any configuration commands to GPS, then host needs to be in Master or Multi master mode.
- + While Host (MCU) is in Master/Multi-Master mode, the following can be changed:
 - 1) Clock rate can be switched to 100KHz (OSP command).
 - 2) I²C address, (OSP command)
 - 3) OSP/NMEA mode
 - 4) GPS can be turn into a Slave mode by sending OSP Message ID 178, Sub ID 2 input command.

Change the GPS module from Multi master to Slave mode:

- a. change from NMEA to OSP - "\$PSRF100,0,115200,8,1,0*04\r\n".
- b. Change to Slave mode with 400Kbps, send:
A0 A2 00 48 B2 46 01 8C BA 80 03 FF 00 00 0B B8 09 0B 38 F9 00 01 11 52 11 52 00 00 00 00 00 00 00 52
00 00 00 00 00 41 00 00 00 00 00 00 00 00 00 00 00 00 00 00 01 C2 00 00 00 62 00 60 01 00 01 F4 2A 00 00
00 00 00 00 00 00 00 00 09 C8 B0 B3 0D 0A
- c. Read 128 Bytes at least from the GPS module, and then immediately without any delay send the next OSP message.
- d. If you want to switch back from OSP to NMEA please use command
A0 A2 00 18 81 00 01 01 01 01 01 01 05 01 01 01 01 01 00 01 00 01 00 01 01 01
01 12 C0 01 68 B0 B3 0D 0A

GPS multi master	Host Salve
I ² C address '0x60'	I ² C address '0x62'
GPS slave	Host Master
I ² C address '0x60'	I ² C any address